

Séries
NSX

SIZE 5 SOCKET COAX CONTACT
FOR S280W503-2 CABLE
BOEING P/N: BACC47EU-4

Issue:
09 FEB.94

Page
1 / 1

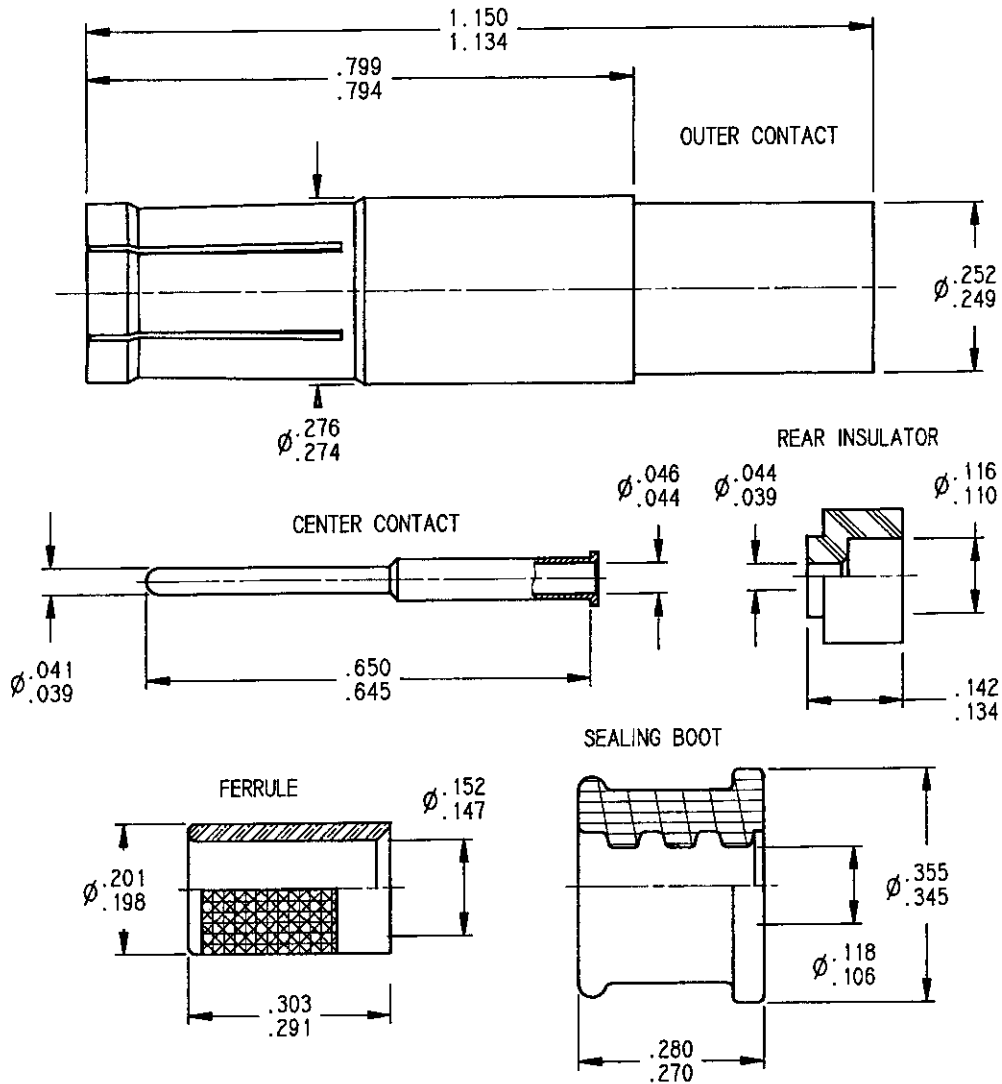

MATERIAL:
 OUTER CONTACT: BERYLLIUM COPPER HEAT TREATED FOR SPRING TINES
 INSULATOR: TPFE
 CENTER CONTACT: BRASS PER QQ-B 626
 FERRULE: BRASS
 SEALING BOOT: SILICONE ELASTOMER
FINISH (ALL METAL PARTS)
 GOLD PLATE PER MIL-G-45204: 50 MICROINCHES OVER NICKEL

DESIGN REQUIREMENTS
 TEMPERATURE RANGE: -65°C TO +165°C
 IMPEDANCE: 50 OHMS NOMINAL
 RATED VOLTAGE: 325 V RMS AT SEA LEVEL
 VSWR: 1.30:1
 FREQUENCY RANGE: 0 - 500 MHZ
 CONTACT RESISTANCE: 1.0 MILLIOHMS MAX (OUTER CONTACT)
 DIELECTRIC WITHSTANDING VOLTAGE: 750 VRMS AT SEA LEVEL

CONTACT SHALL ASSEMBLE USING TOOLING AND STRIP LENGTHS ACCORDING TO RP08710

CREATION					
PEN:					
NOM: JP MACARI					
DATE: 23 DEC. 93	09.02.94	CHANGE FERRULE SHAPE Ø.201/.198 WAS .193/.191 Ø.152/.147 WAS .150/.147	JP MACARI		
APPR.: <i>JP MACARI</i>	Issue	Revisions	Name	Approved	

This information is given as an indication. In the continual goal to improve our products, we reserve the right to make any modifications judged necessary.